

 **First** in Quality. Built to **Last**.

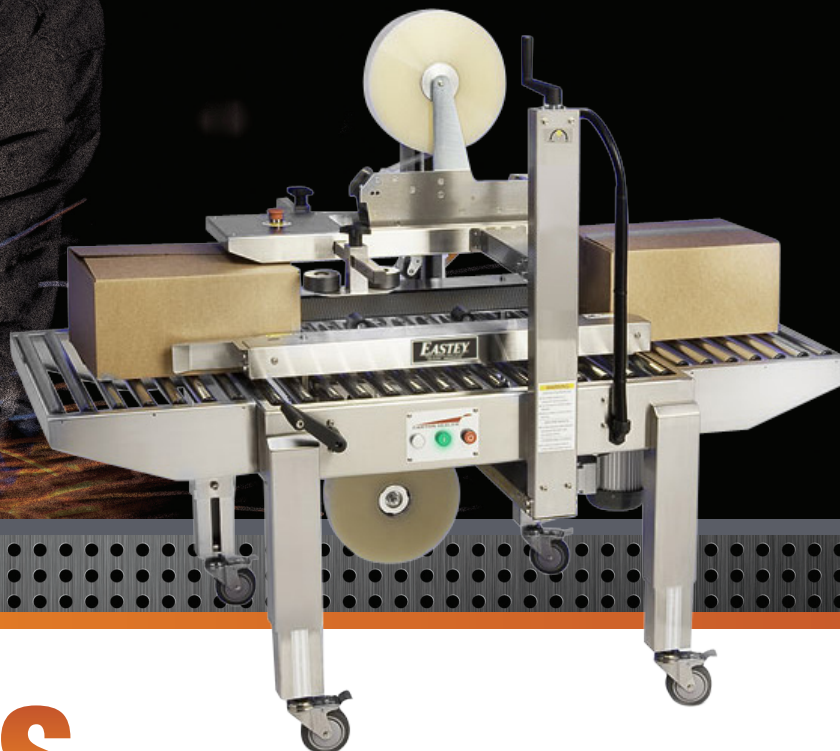

SB-2EX-SS

SIDE BELT CASE TAPER

MAXIMUM UPTIME

Eastey's SB-2EX-SS Case Taper offers the quality that you have come to rely on from Eastey. The system's unique and simple design has proven to be one of the most reliable case tapers on the market today, keeping production and maintenance efforts to a minimum and providing fast and efficient alternatives to hand taping.

WIDE STANDARD CASE RANGE

The SB-2EX-SS's side belts are great for light or heavy weight, narrow or small boxes. It is ideal for void-fill cases where the packaged product does not support the box.

INDUSTRIAL STRENGTH OPERATION

Dual 1/4 hp drive motors, aggressive industrial strength drive belts, and roller tables make SB-2EX-SS a workhorse that will stand up to your toughest challenges. Each case taping machine is made from 12 gauge stainless steel that will withstand even the most rugged applications. A powder coated exterior protects the machine from abusive conditions and guarantees years of use. Best of all, the SB-2EX-SS is CE certified, so users can be confident it will consistently provide reliable, high quality case sealing.



WIDE STANDARD CASE RANGE

The SB-2EX-SS's side belts are great for light or heavy weight, narrow or small boxes. It is ideal for void-fill cases where the packaged product does not support the box.

PRODUCTION MEETS VERSATILITY

SB-2EX-SS offers fast and easy case changes with adjustable side rails and flexibility for boxes 5" long and greater. Adjustments can be made on the fly with easy hand tighten knobs and cranks which can be attached to either side of the machine. SB-2EX-SS utilizes easy to load top and bottom tape cartridges and will seal boxes as narrow as 4.5" wide and as low as 4.5" tall.

CASE TAPING MADE EASY

SB-2EX-SS is designed and built with the customer in mind. Top and bottom tape cartridges are interchangeable and designed for easy tape threading. These machines accept 2" wide pressure-sensitive tape as a standard, or can be converted in the field with 3" tape heads for wider case taping applications. Operators can learn to use Eastey's SB-2EX-SS case taping machine in minutes, avoiding breaks in production and downtime, saving your company money and increasing your ROI.

THE RIGHT SOLUTION

Rugged design. Proven reliability. Simple operation. Your benefits go on and on. When it comes to industrial operation, rely on Eastey to provide the right solution for your case sealing needs.

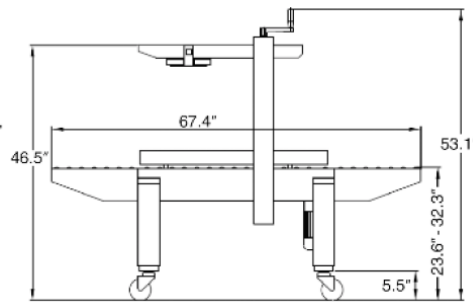
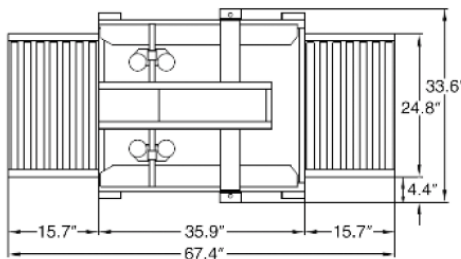
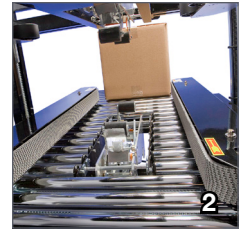
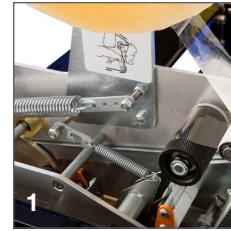

1. Top and bottom tape heads are interchangeable and are designed for easy threading
2. Industrial strength roller beds move boxes consistently through the taper
3. Adjustable side rails and tape head offer fast and easy case changes
4. Top and bottom tapeheads are identical and can be removed instantly without tools. Choose from two options.

SB-2EX-SS FEATURES

- Plug-in and go operation
- Fast and easy box size changes
- Industrial strength side belts
- Interchangeable top and bottom tape cartridges
- Emergency stop button
- Adjustable leg extensions
- Casters for transportation within plant
- Front and rear pack tables to allow for case packing
- Top squeezers push top flaps together for accurate case sealing
- 12 gauge stainless steel
- Low maintenance, no air required

SB-2EX-SS TAPING SPECIFICATIONS

Sealer Type	Side belt, top and bottom case sealer
Machinery Makeup	Industrial strength 12 gauge steel
Belt Speed	75 fpm
Tape Speed	30 cases per min., depending on box size and operator efficiency
Height Adjustment	Standard adjustable legs for 18.1" to 32.3" conveyor heights

BOX SPECIFICATIONS

	Length	Width	Depth
Minimum Box Size	5"	4.5"	4.5"
Maximum Box Size	Infinite	19.5"	19.5"

Tape Size	2" wide pressure sensitive tape, up to 15" diameter rolls, optional 3" wide tape
Tape Cartridge	Proven design requires no lubrication, designed for simple tape threading, removable for maintenance and interchangeable with top or bottom cartridges
Drive Motor	Two (2) 1/4 HP drive motors
Electrical Requirements	110 VAC, 60Hz, 4.0A
Agency Approvals	CE Certification

SB-2EX-SS OPTIONAL ACCESSORIES

3" Tape Head	Accepts 3" wide tape rolls
--------------	----------------------------



7041 Boone Avenue North, Brooklyn Park, MN 55428
 (763) 428-4846 1 (800) 835-9344
 www.eastey.com info@eastey.com



ENGAGE technologies corporation